

PV Powered Induction Motor Drive for Water Pumping

Sandesh G. Shete, Sanjay S. Dhamse

Abstract- In the rural area the solar photovoltaic fed induction motor drive system is the most efficient system to pump the water for drinking water, water treatment and agricultural purpose. Life in rural area is without electricity due to the increasing demand of electricity and increasing cost of fossil fuel. This paper deals with the implementation of photovoltaic power to drive the three phase induction motor by integration of boost converter topology with constant voltage control scheme and three phase inverter with SPWM control strategy. This system can satisfy the basic need of life without electricity in rural area. The performance of proposed system is obtained for fixed radiation and constant ambient temperature. The boost converter topology is used to step up the input voltage. The desired output of boost converter is obtained by the constant voltage control technique. The three phase inverter is controlled by SPWM control technique. The whole proposed work carried out in MATLAB/Simulink environment using SimPower system and Simscape tool box.

Index Terms- Boost converter, Photo voltaic module, SPWM, STC, Three phase inverter, Three phase IM.

1 INTRODUCTION

Renewable energy generally defined as energy that collected from resources which are naturally replenished on a human timescale, such as sunlight, wind, rain, tides, wave geothermal heat. Renewable energy often provides energy in four important areas: electricity generation, air and water heating and cooling, transportation and rural energy services [1]. Solar energy, radiant heat from the sun, is harnessed using a range of ever evolving technologies such as solar heating, photovoltaic, concentrated photovoltaic, solar architecture and artificial photosynthesis. From the above different technology a photovoltaic system converts light into electrical direct current by taking advantage of photovoltaic effects. Solar PV has turned into multibillion, fast growing industry, continuous to improve the cost effectiveness.

Generation and consumption of Power or Electricity play very important role in economic growth and well-being of nation. The existence and development of adequate infrastructure is essential. The persistent growth of the Indian economy is necessary for the fast journey to become developed country from developing country. Due to this fast journey, the demand for Electricity in the country has been growing at very faster rate and it is to be expected to grow further in the years to come [1,2].

During these recent years, the progress in semiconductor devices has led to spike in the performance of equipment used in power electronics for renewable energy applications. The human concern for the environment and the way our current technology deteriorates has launched scientists and engineers

around the world in the search of cleaner renewable energy resources on which to rely on. One such resource comes from our closest star; the Sun. Photovoltaic is the method responsible for the conversion of solar radiation energy into useful electrical energy. Such application is being enthusiastically developed industrially, commercially, and even residentially. This scenario becomes highly advantageous when dealing with some of the most essential human needs worldwide, such as the availability of clean drinking water. Water treatment devices may be used for such applications, relying on solar powered modules. The power electronics converter provide necessary means to convert the constant voltage output obtained from photovoltaic module to usable alternating power source with whom we drive the three phase induction load [3].

The squirrel cage induction motor is most versatile in drive application due to less maintenances. Cost effective and rugged construction. This paper present a standalone solar PV based induction motor drive for water pumping system. In the proposed control scheme duty cycle of high boost converter is controlled to DC voltage at required level. The speed of induction motor drive is a function of solar irradiation. The performance of the developed system has been analyzed by simulation [4].

2 PROPOSED SYSTEM AND BLOCK DIAGARM

This paper proposed a new pumping system which eliminate the need of battery, thereby reducing the initial investment and also increasing the lifetime of the system significantly. Fig.1 presents the proposed PV system. This include a solar photo voltaic module, a boost converter, a three phase SPWM controlled inverter, and a three phase induction motor.

- Sandesh G. Shete, persuing masters degree program in electrical machine and drive, Goverement College of Engineering, Aurangabad, India, E-mail:sandesh411@gmail.com.
- Sanjay S. Dhamse, Associate professor, Goveremnt College of Engineering, Aurangabad, E-mail:ssdhamse@yahoo.co.in.

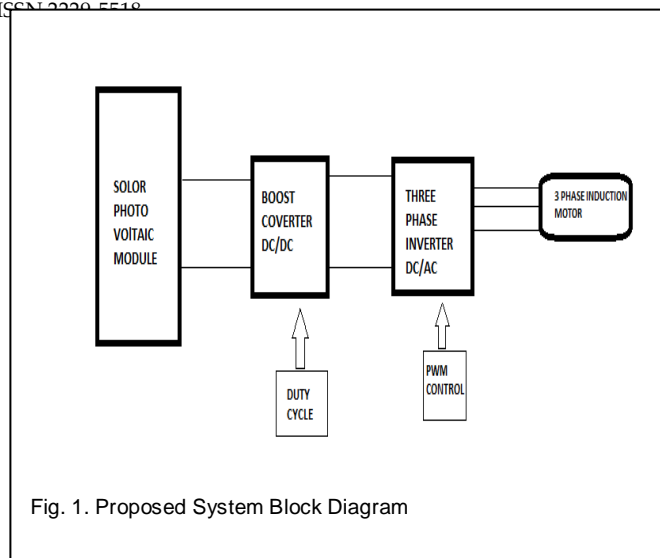

Fig. 1. Proposed System Block Diagram

This proposed system does not require the battery so it overcome the problems of battery and improve the life span of overall system. Three phase induction motor is selected because of its low cost, availability in market and low maintenance cost. This proposed system is adequate solution for drinking water supplies in rural area as well as grid connected areas. So proposed system will give unique solution

- To reduce growing demand of electricity for water pumping to lift the water from low level to high level
- To supply water in rural area with low cost
- To make the system independent on cost and availability of fuels
- To create pollution free environment.

3 DEVELOPMENT OF PROPOSED SYSTEM

3.1 Modelling of Solar PV Module

A material or device that is capable of converting the energy contained in photons of light into an electrical voltage and current is said to be photovoltaic. A photon with short enough wavelength and high enough energy can cause an electron in a photovoltaic material to break free of the atom that holds it. If a nearby electric field is provided, those electrons can be swept toward a metallic contact where they can emerge as an electric current. The driving force to power photovoltaic comes from the sun, and it is interesting to note that the surface of the earth receives something like 6000 times as much solar energy as our total energy demand [11].

An Equivalent circuit of PV cell

A simple equivalent circuit model for single PV cell consists of a real diode in parallel with an ideal current source as shown in fig. 2. The ideal current source deliver current in proportion to the solar flux.

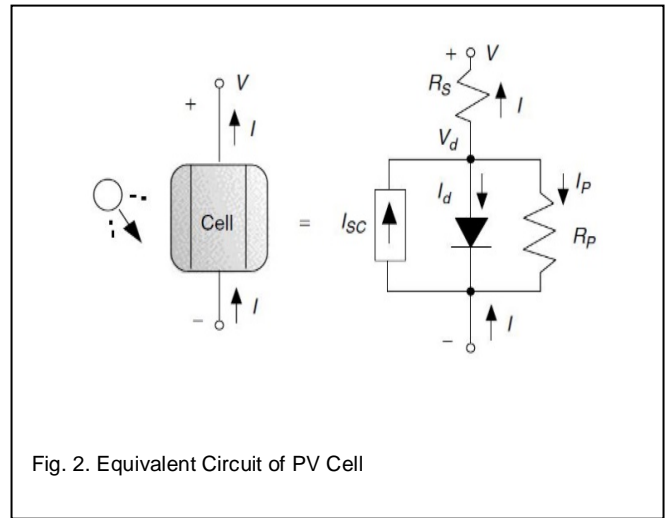

Fig. 2. Equivalent Circuit of PV Cell

There are two conditions of particular interest for the actual PV and for its equivalent circuit as shown in fig. 3. They are-

- The current that flows when the terminals are shorted together (the short-circuit current, I_{sc})
- The voltage across the terminals when the leads are left open (the open-circuit voltage, V_{oc}).

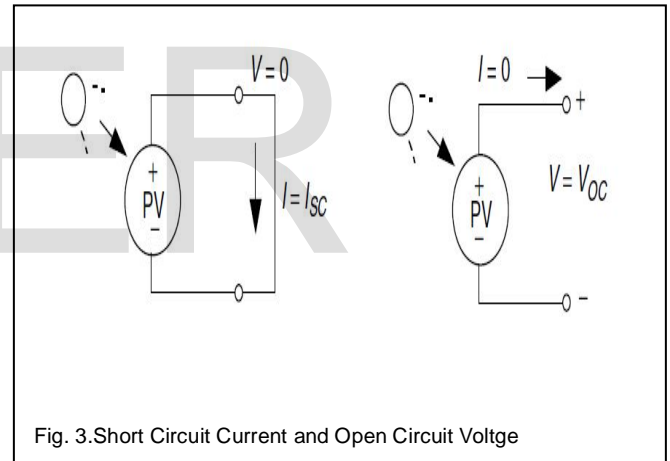

Fig. 3. Short Circuit Current and Open Circuit Voltage

When the leads of the equivalent circuit for the PV cell are shorted together, no current flows in the (real) diode since $V_d = 0$, so all of the current from the ideal source flows through the shorted leads. Since short-circuit current must equal I_{sc} , the magnitude of the ideal current source itself must be equal to I_{sc} [11].

Now the voltage and current equation for the equivalent circuit of the PV cell is below

$$I = I_{SC} - I_D \tag{1}$$

$$I = I_{sc} - I_o(e^{\frac{qV}{kt}} - 1) \tag{2}$$

$$V_{oc} = \frac{kT}{q} \ln\left(\frac{I_{sc}}{I_o} + 1\right) \tag{3}$$

For fixed irradiation and 25°C

$$I = I_{sc} - I_o(e^{38.9V} - 1) - \frac{1}{Rp}(V + IR_s) \tag{4}$$

$$V_{oc} = 0.0257 \ln\left(\frac{I_{sc}}{I_o} + 1\right) \tag{5}$$

In both of these equation (4) and (5) short circuit current I_{sc} is directly proportional to solar radiation [11].

Formation of PV Module

Since an individual cell produce only about 0.6 volts, so for the formation of the basic building block of PV application module consisting of pre-wired cells in series, all encased in tough, weather resists package. Atypical module as shown in fig. 4 has 36 cell in series and is often designated as a "12-V module" even though it is capable of delivering much higher voltage than 12 V.

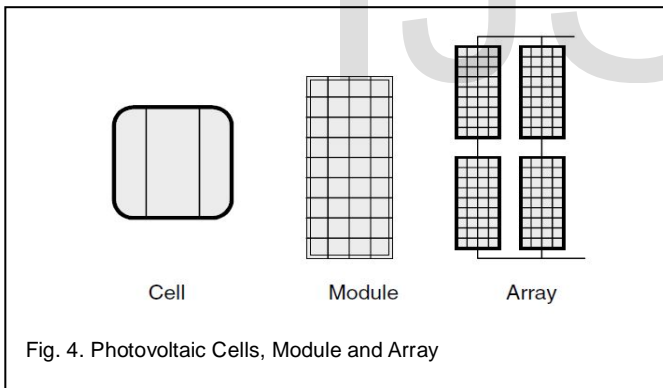

Fig. 4. Photovoltaic Cells, Module and Array

Module can be wired in series to increase the voltage and in parallel to increase current array are made up of some combination of series and parallel module to increase power.

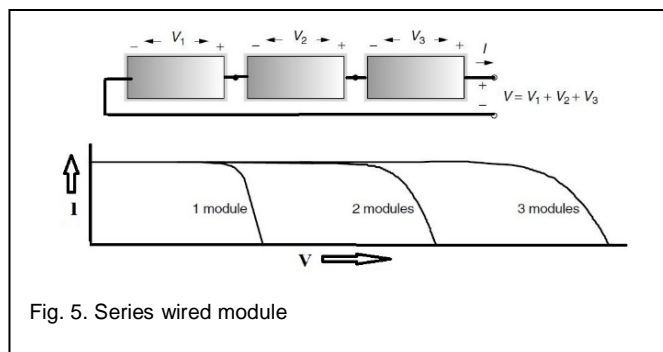

Fig. 5. Series wired module

For module in series, the I-V curve are simply added along

the voltage axis, at any given current the total voltage is just the sum of individual module voltage as shown in fig. 5.

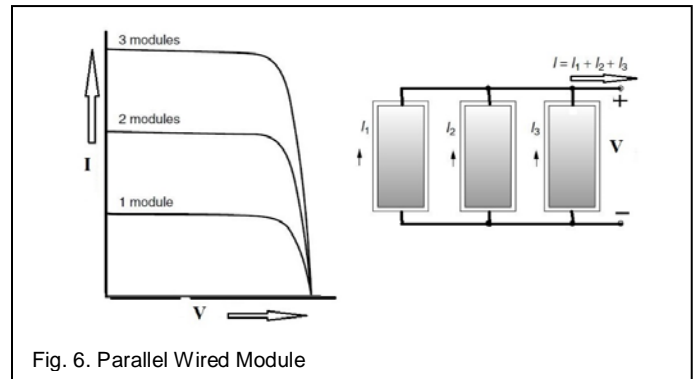

Fig. 6. Parallel Wired Module

For module in parallel, the I-V curve of the parallel combination is just the sum of individual module current at any given voltage as shown in fig. 6.

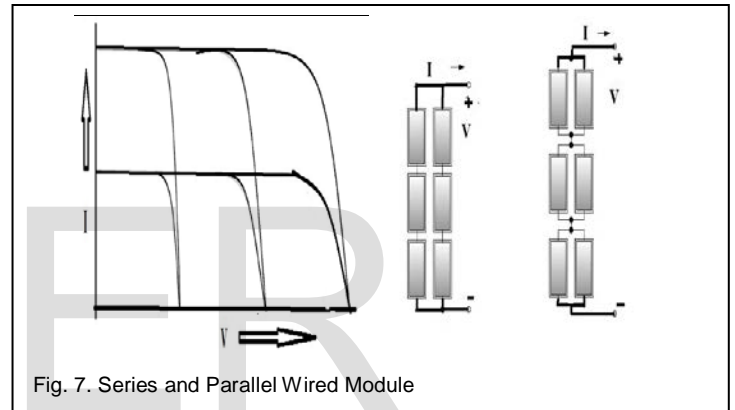

Fig. 7. Series and Parallel Wired Module

When the high power is needed, the array usually consists of combination of series and parallel module as shown in fig. 7. The total I-V curve is sum of individual module [11].

3.2 THE BOOST CONVERTER TOPOLOGY

The boost converter is needed to efficiently convert DC voltage from lower level to higher level [10]. In boost converter the output is greater than input voltage hence name as "boost". For lossless converter the port variable are related to the duty ratio D by the relation [3, 10].

$$V_o = \frac{V_s}{(1 - D)} \tag{6}$$

$$D = \frac{t_{on}}{T} \tag{7}$$

The peak to peak ripple current of inductor L is given as

$$\Delta I = \frac{V_s(V_o - V_s)}{fLV_a} \tag{8}$$

The peak to peak ripple voltage of capacitor is given as

$$\Delta V_c = \frac{I_o(V_o - V_s)}{V_o f C} \tag{9}$$

The value of inductance respectively the capacitance C of converter are calculated at the boundary operation condition of the circuit as follows

$$L = \frac{(1 - D)DR}{2f} \tag{10}$$

$$C = \frac{D}{2fR} \tag{11}$$

The boost converter is modelled using SimPower system block in MATLAB /Simulink environment. The command signal is obtained through comparator having switching frequency 10 kHz.

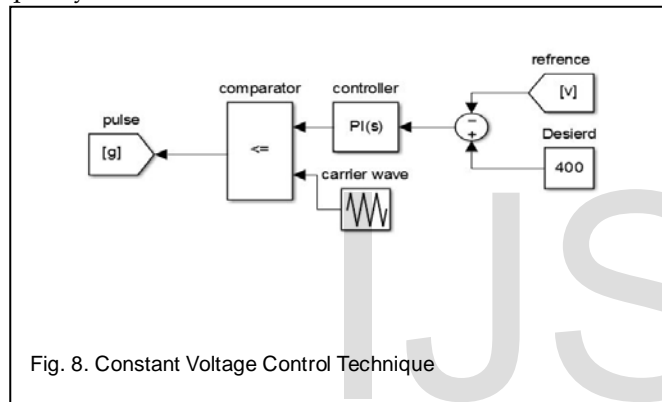

Fig. 8. Constant Voltage Control Technique

Fig. 8 shows the block diagram of constant voltage controlled technique. The desired output is set to the 400V. The output of PI controller is compared with carrier wave to generate the switching pulses for the boost converter.

3.3 Inverter Circuit Topology

A three phase inverter is used for converting the boosted DC output from DC-DC converter to the AC for the operation of three phase induction motor. For the best result an SPWM controller is used to drive the gate of the switches used in the inverter [6]. Inverter generates at any required voltage or frequency by proper switching and control technique. There are single phase and three phase inverters but the three-phase inverters are commonly used in high power applications. This inverter consists of three half-bridge units, the switching devices can be IGBTs, BJTs, and GTOs. Fig. 9 shows the inverter circuit. The controlling of switches depends on the required power level, desired frequency. When upper switch is turned on the corresponding lower switch should turn off and vice versa.

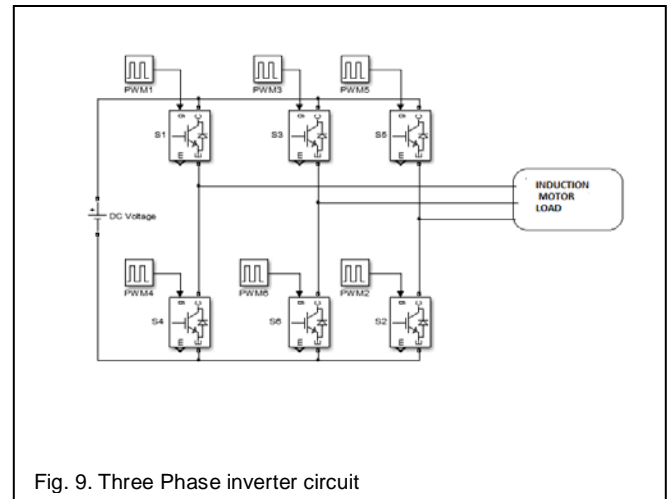

Fig. 9. Three Phase inverter circuit

In 3-ph inverters gating pulses are delayed by 120 degrees with respect to each. Six modes of operation are possible for each cycle and has interval of 60 degrees. Therefore 3-ph voltages lag by 120 degrees. The inverter output is a square waveform when it is not connected to a transformer. This square waveform can be converted to sine waveform by using LC low pass filter [6].

3.4 SPWM Controlled Technique

In PWM control, the output voltage is controlled by varying the width of pulses, if there are P-pulse per half cycle, the maximum pulse width is π/P . It is possible to choose the width of pulses in such way that certain harmonics could be eliminated. There are many methods of obtaining pulse with different widths. The most common one is the sinusoidal pulse-width modulation (SPWM). In this technique, the pulse width are generated by comparing a triangular voltage V_r of amplitude A, and frequency f_r with a carrier half sinusoidal voltage V_c of variable amplitude A_c and frequency of f_s [12].

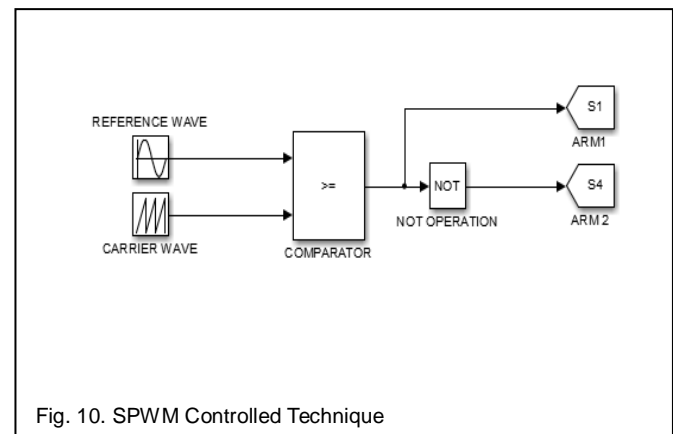

Fig. 10. SPWM Controlled Technique

Fig. 10 shows control strategy the reference wave is compared with the carrier wave so the gate pulse is generated after the comparator operation. The output of comparator is fed to the Arm 1 of bridge inverter.

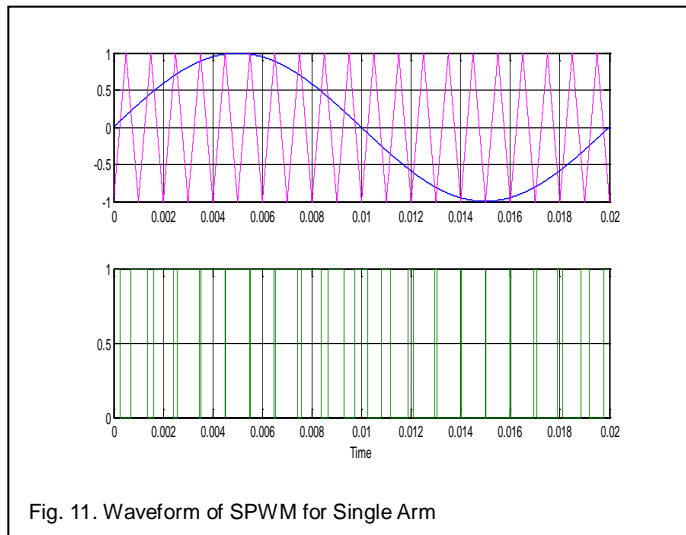

Fig. 11. Waveform of SPWM for Single Arm

Fig. 11 shows the waveform of signal obtain from SPWM achieved by Matlab/Simulink model and respective gate pulse. The Amplitude modulation index is defined as

$$M_a = \frac{V_m}{V_{cr}} \quad (12)$$

Where,

V_m is the peak amplitude of the reference voltage waveform
 V_{cr} is the peak amplitude of the triangular voltage waveform
 The output voltage is controlled by changing the modulation index M from 0 to 1.

3.5 Induction Motor

The three phase induction motor is an electrical to mechanical conservation device and it is an asynchronous AC machine because the rotor speed is always less than stator magnetic speed. The construction of IM is rugged and cheap therefore it is widely used in many application like in elevator, water pumping system and in industry [7]. The three phase induction motor is still very attractive for wide range application due to its robust construction and low cost.

4 SIMULATION RESULTS AND DISCUSSION

The I-V and P-V characteristics of PV module are shown in fig.12. For the module type SRP 305-WHT the different I-V curve and P-V for different temperature condition is shown. Considering standard test condition (STC) specific data of a solar module are measured under STC. STC are defined as the solar irradiance of 1000 W/m^2 , a module temperature of 25°C . The open circuit

voltage of single module is 64.2 V , and short circuit current is 5.96 A . So by connecting the module in series and one module in parallel the PV array is formed. This PV array can produce max 1.2 Kw power to feed the three phase induction motor

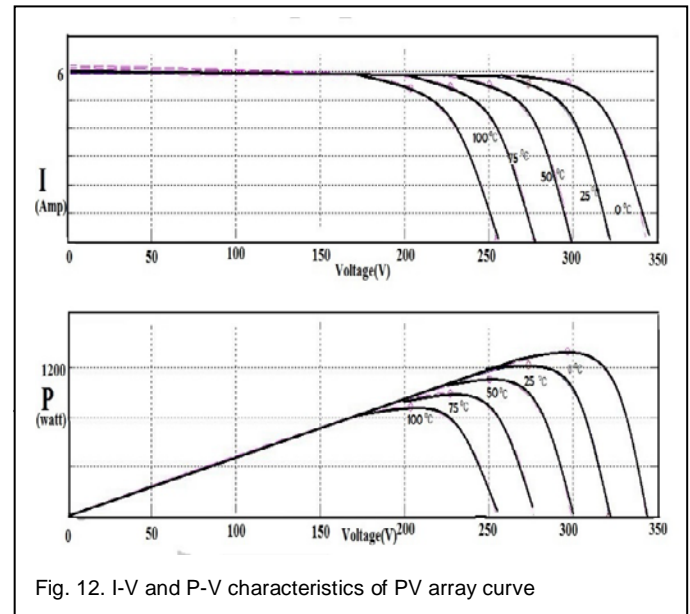

Fig. 12. I-V and P-V characteristics of PV array curve

Considering the STC the solar irradiance is kept for 1000 w/m^2 and temp of 25°C for the better efficiency of the panel. The input of PV array is as shown in fig. 13. Solar irradiance and temperature is kept under STC condition. The irradiance is change for few cycle to observe the effect on the output.

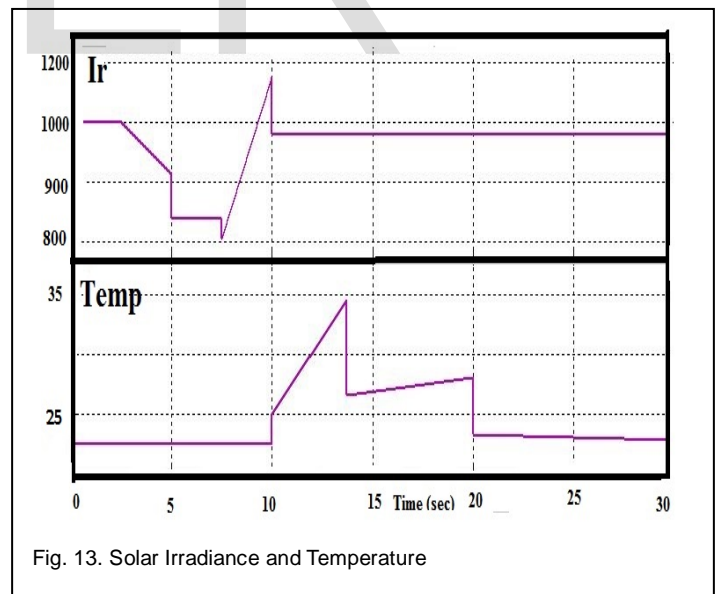

Fig. 13. Solar Irradiance and Temperature

The output of PV array module is shown in fig. 14. For the given input of PV array the output is observe. In fig. 14, It clearly seen that the PV output voltage is obtained is near to 300 V and PV output current is near to 5 amp so the PV array is design at rated power output of 1.2 kW .

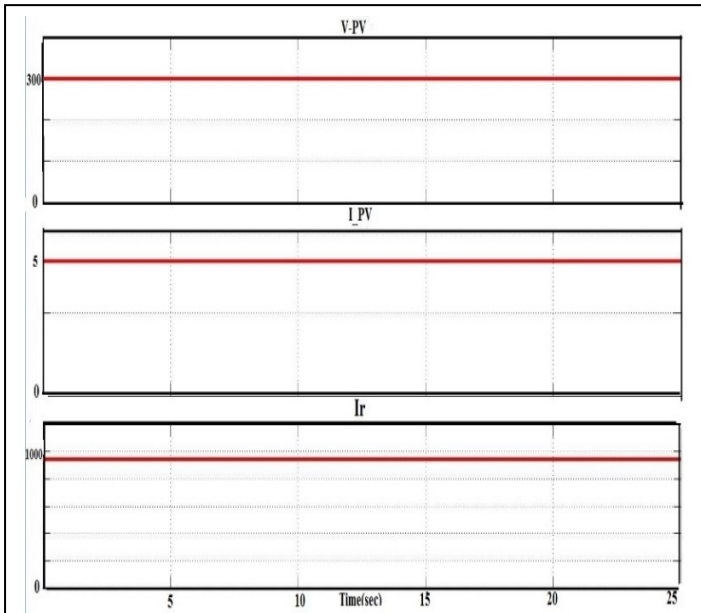

Fig. 14. PV Array Output

Constant voltage control technique is used to get desired output at 400 V. The frequency of carrier wave is set to 10 KHz. The PI controller is used to get switching pulse to DC-DC converter. The output of boost converter is 400 V as shown in fig. 15.

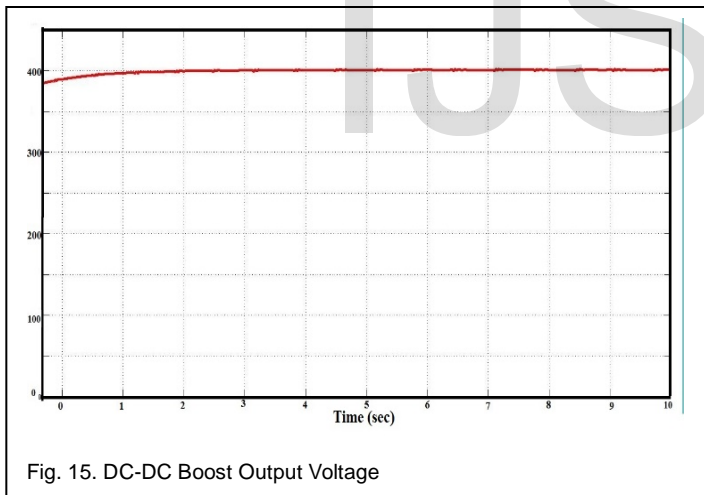

Fig. 15. DC-DC Boost Output Voltage

As shown in fig. 16 it is the phase voltage of inverter output. Boosted output voltage is obtained from boost converter is fed to three phase inverter. The simple SPWM controlled technique is used to the controlled the gate pulse of inverter. The carrier wave frequency is set to the 10 KHz and amplitude of 1. Reference wave frequency is at 50 Hz and amplitude of 0.8.

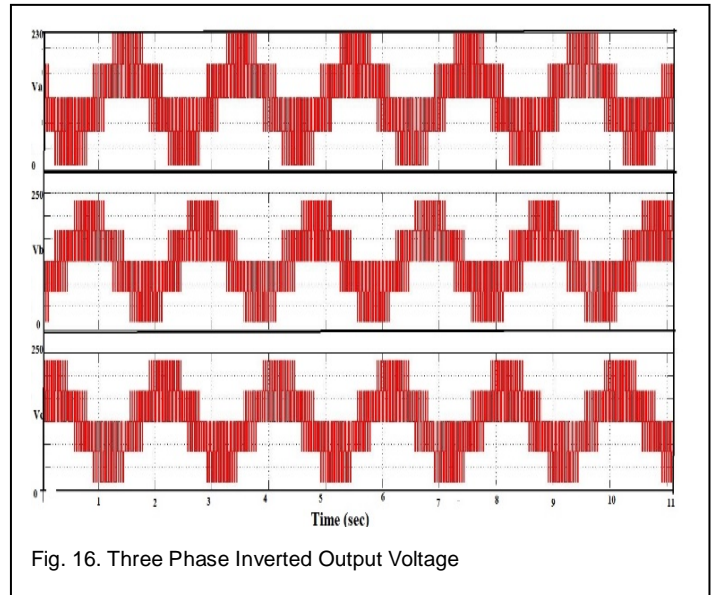

Fig. 16. Three Phase Inverted Output Voltage

The induction motor of 1 HP, 400 V, 50 Hz is operated at given inverter output. From Fig. 17 it clearly seen that the three phase induction motor is operated at rated speed of 1440 rpm. The rotor speed variation from stationary to running condition is observe.

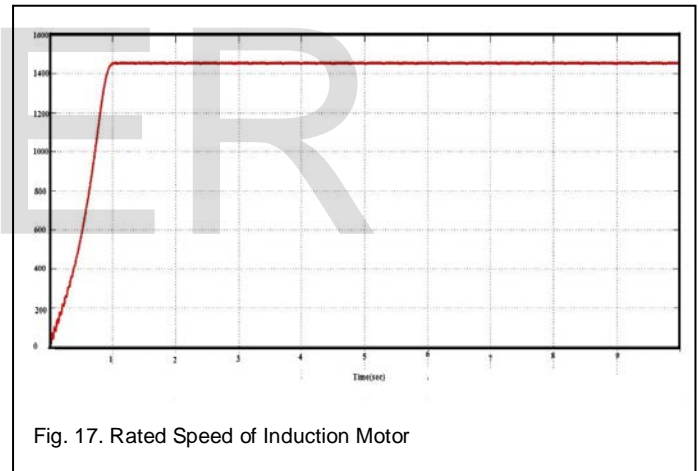

Fig. 17. Rated Speed of Induction Motor

The variation in torque starting is observed which occur due to heavy inrush current. Steady torque is obtained after few cycle as shown in fig. 18.

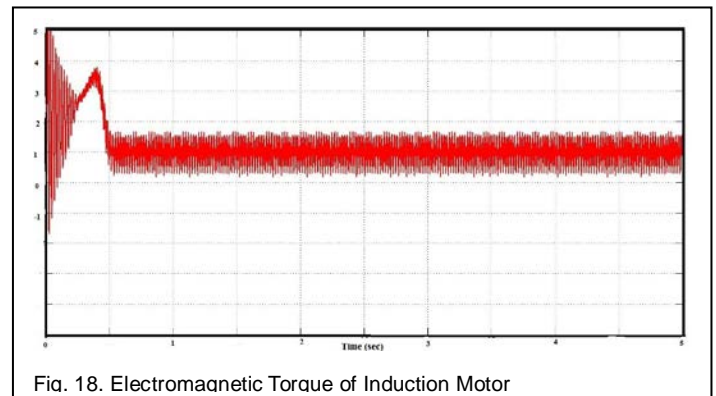

Fig. 18. Electromagnetic Torque of Induction Motor

5 CONCLUSION

A standalone solar PV system has been modelled for the induction motor drive used in water pumping system. Solar PV water-pumping systems are simple, reliable, conserve energy and need less maintenance. A solar PV system fed induction motor via series integration circuit of boost converter with constant voltage control and inverter with SPWM control technique has been presented. Simulation result shown that the induction motor can be effectively operated by the PV system. This system can increase its utilisation in rural areas and grid connected residential areas because of its excellent performance, low cost and ease operation.

APPENDIX

PV module specification	Sun Power SPR-305-WHT, No cell per module=96, Voc=64.2 Volt, Isc=5.96 A, 1.2kW power capacity
Boost converter specification	Inductor =0.0230H, Capacitor=50 μ f, Switching frequency = 10 kHz
Three phase induction motor specification	1 Hp,400V, 50Hz, 4 pole , 1440 rpm, Stator resistance =1.9 Ω , Stator inductance = 0.02301 H, Moment of inertia=0.04 kg.m ²

REFERENCES

- [1] Indian power sector analysis report- April 29, 2015, www.ibef.org/industry/powersectorindia.
- [2] Jyoti ugale, Dr M.S pansa, "Single phase AC drive Isolated solar photovoltaic water pumping system", *ICGCIOT, International conference*, pp. 1285-1287, 2015.
- [3] N. Mendez-Gomez, O. Bousono, R Castaneyra, and E.Ortiz-Rivera, "Development of a low cost induction motor drive system using a PVM, boost converter and three-phase inverter", *Proc. IEEE Photovoltaic Specialist Conference (PVSC)*, pp. 1348-1351, 2012.
- [4] Jayadeep Srikolapu, Bhoopendra singh, Tashi Sharma and Harish Ahmed, "Solar water pumping system employing induction drive with high level boost converter", *PHICON 6th IEEE*, pp. 1-7, 2014
- [5] Dhanesh Radhakrishan, S.sathneesh Kumar, "Optimization of PV water Pumping system with direct driven induction motor", *ICIIECS, IEEE sponsored international conference*, pp. 1-5, 2015.
- [6] D.Venkta, Anil sairam, B venkta Ramana, "V/F speed control of based solar fed induction Motor", *IJAIEEM*, Volume 3, Issue 11, November 2014.

- [7] Menka dubey, shailendrasharma, member IEEE and rakesh saxena, "Solar PV stand-alone water pumping sytem employing PMSM drive", *IEEE electrical ,electronics and computer science IEEE students conference*, pp. 1-6, 2014.
- [8] E. Ortiz-Perez, R. Maldonado, H. O'Neill, and E.1. Ortiz Rivera, "Proposed system model and simulation for three-phase induction motor operation with single PV panel," *Proc. IEEE Power and Energy Society (PES) General Meeting*, pp. 1-6, 2011.
- [9] J. V. Mapurunga Caracas, G. de Carvalho Farias, L. F. Moreira, L. A. de Souza Ribeiro, "Implementation of a High-Efficiency, High-Lifetime and Low-Cost Converter for an Autonomous Photovoltaic water Pumping System", *IEEE transaction on Industry Applications*, Vol-50, no.1, Feb 2015, pp. 631-641.
- [10] Muhammad H. Rashid, *Power Electronics Circuit, Devices and Application*, Third edition, 2012, pp. 191-198.
- [11] Gilbert M. Masters, *Renewable and Efficient Electric Power Systems*, John Wiley & sons, Inc., publication, pp. 456-470.
- [12] Deodatta shingare, *Industrial power electronics, Electrotech publication*, pp. 176-177.